

# Yahtzee<sup>®</sup> DELUXE POKER

## INSTRUCTIONS

AGES: ADULT

For 2 to 6 Players



### Object

Roll dice combinations to win cards and chips.

Win the game by having at least one card and the most money after seven rounds of play.

### Contents

Dice rolling tray with insert, 5 dice, 36 cards,  
6 tokens, 46 \$100 chips, 22 \$500 chips,  
46 \$1,000 chips, label sheet.

## The First Time You Play

Carefully separate the cards and tokens from the sheet. Remove the chips and dice from their bags. Discard the bags and the cardboard waste.

### Assemble the Tray

1. Carefully apply the two tray labels as shown in Figure 1.

Figure 1

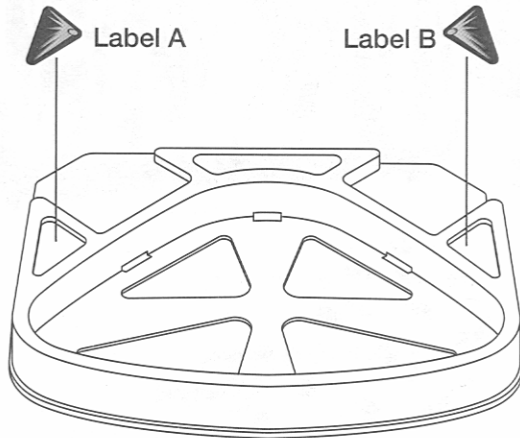

2. Fit the insert into the tray by carefully bending it and sliding the tabs into the tray slots. See Figure 2.

Figure 2

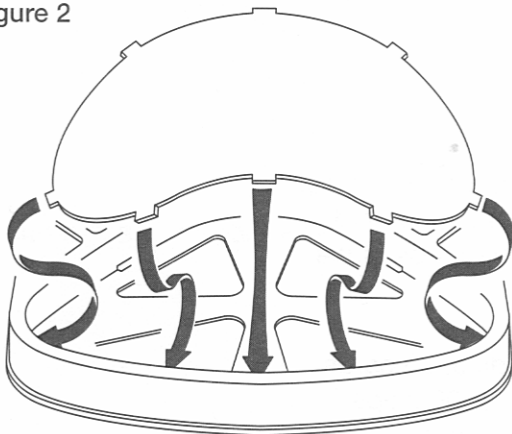

## Game Setup

1. Shuffle the 36 cards. Choose seven cards at random and stack them facedown in the tray. See Figure 3. Place the remaining cards out of play.

Figure 3

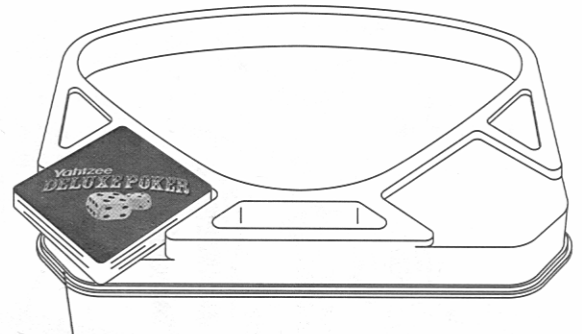

2. Each player takes one token. Place any extra tokens out of play.
3. Choose a player to be the banker. This player will give out (and take away) chips during the game. The banker now gives each player \$1,500 worth of chips: 5 \$100 chips and 2 \$500 chips.

## Playing the Game

The game consists of seven rounds. Play one card per round.

**The cards:** Each card shows a 5-dice combination. Your goal is to roll dice that match the dice pictured on the card, in a certain amount of rolls or less.

If you're successful, you win the card and its payout (dollar value) in chips. If not, the round continues until all of the dice on the card are matched.

The examples shown below illustrate card features and gameplay.

**Important:** Jokers are wild. Special rules for matching jokers are explained on page 4.

## CARD EXAMPLES

### Dice combination

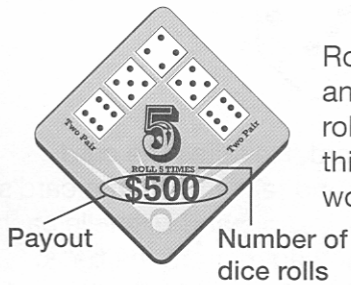

Roll 2 sixes, 2 fives and 1 four in 5 dice rolls or less, to win this card and \$500 worth of chips.



Roll 4 ones and 1 die of any other number (to match the joker) in 4 rolls or less, to win this card and \$800 worth of chips.



Roll 5 matching dice of any number in 3 rolls or less, to win this card and \$1200 worth of chips.

## A Round of Play

On each round of play, follow the 3 steps below. The Sample Round on pages 5 and 6 illustrates one round of play in a 4-player game.

### 1. Players Bid

In this step, players call out bids for the right to roll dice to match those on the card. The highest bidder rolls dice to win the card and its payout - hundreds of dollars in chips!

**Who bids first?** The player who owns the game (it's only fair) opens the bidding for the first card in play.

The opening bidder takes the top card from the stack and places it faceup on the “in play” section of the tray. See Figure 4.

Figure 4

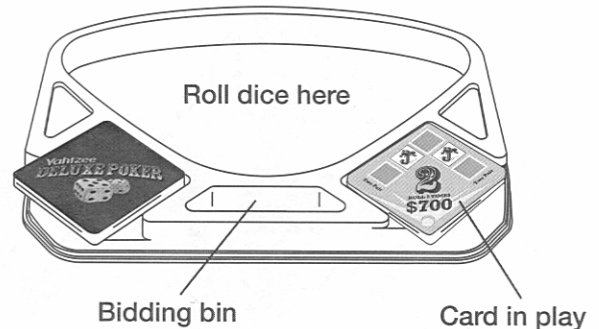

The opening bidder calls out a dollar amount of at least \$100 – or passes and lets any other player call out a bid. (If everyone passes, the opening bidder wins the bid for free).

Players may now “up the ante” by calling out higher and higher bids. The opening bidder may also join in.

Bidding is often a frenzied free-for-all. Players may bid any number of times, in any order, and may start, stop or jump in again at any time. Bid any amount divisible by \$100, as long as you have enough chips. However, you should avoid bidding more than the payout unless you're desperate to win a card, or want to prevent an opponent from doing so.

**Caution:** Bid with care! Overly aggressive bidding may quickly wipe out all of your chips and end your participation in the game!

Bidding continues until no one tops the highest bid, or until someone calls out “All-In!” (See *All-In* section on page 4.) Whoever bid the highest amount (or called “All-In!”) becomes the *Rolling Player*. This player now places chips equaling the amount of his or her bid into the bidding bin. See Figure 4.

### 2. Players Bet

Any or all *other* players may bet on whether or not the Rolling Player will succeed.

To bet, turn your token “yes”-side up if you think the Rolling Player *will* succeed. Turn your token “no”-side up if you think the Rolling Player won’t succeed. Then place your wager (up to \$300) beside your token. You’ll win this amount of money if you’re right, and lose it if you’re wrong.

### 3. Rolling Player Rolls

If you’re the Rolling Player, roll all 5 dice into the tray. (Reroll any leaning dice or dice that land outside of the tray.) Then place matching dice directly on top of the card’s dice pictures. If necessary, reroll remaining dice to make more matches. *Keep track of your rolls!* You can’t roll more times than the card allows.

Rules for matching jokers: Jokers are wild. You can match them with any dice rolled, with the following exceptions:

- The first die placed on a joker can’t match any other die pictured or placed on the card.
- Once a die is placed on a joker, all *other* dice placed on jokers must be the same number.

*When to match a joker:* You can match the first (or only) joker on any roll, or not at all. If the card has more than one joker, you must decide whether or not to “lock in” the joker value – especially if you can’t complete the card on your last die roll.

**If you don’t complete the card:** You lose your bid (from the bidding bin) to the bank. Any players who bet “no” win their wagered amounts from the bank. Players who bet “yes” lose their wagered chips to the bank.

The card stays in play with any matched dice on it, and the round continues until a player completes the card.

**Continuing a round:** Repeat Steps 1 through 3 with the same card. The unsuccessful player opens the bidding. The player who wins the bid becomes the Rolling Player, who rolls to match *only the unmatched dice*. The payout and the number of dice rolls remain the same.

Repeat Steps 1 through 3 as often as necessary until the card is complete.

**If you complete the card:** You win the card! Reclaim your bid from the bidding bin. The bank gives you the card’s payout. Any players who bet “yes” win their wagered amounts from the bank. *Players who bet “no” pay you (the card winner) their wagers!*

## Beginning a new Round

Players now begin a new round with a new card. The player who completed the last card draws the next card and opens the bidding.

## Out of Money? You’re Out of the Game!

Any player who runs out of chips is immediately eliminated from the game. Luckily, there’s a special *All-In* rule that just might save you from this undesirable fate...

### All-In!

This rule gives you an opportunity to stay in the game. It comes in handy if you’re low on chips or too broke to bid competitively – especially if you haven’t yet collected a card. (Remember, you can’t win the game without at least one card.) Use this option wisely. **Each player may only use it once!**

To use the *All-In* option, do the following during any bidding step:

1. Call out “All-In!” at any time during the bidding – even if the bids have gone higher than you can afford. All bidding stops immediately. You win the bid.
2. Place *all* of your remaining chips into the bidding bin.
3. As the Rolling Player, roll the dice according to the rules – after players have placed their wagers. If you complete the card, you’re back in the game with more cash. If you don’t, you’re out of money, and eliminated from the game.

**Note:** If you were the last opening bidder, the player to your left opens the next bid.

## How to Win

After seven rounds have been played, all players who have at least one card count up their money. The player with the most money wins the game!

### SAMPLE ROUND

Chris, Joe, Michelle and Debbie are just beginning a 4-player game.

#### 1. Players Bid

It's Chris's game, so he opens the bidding for the first round of play.

Chris draws the top card from the stack and puts it in play. To win this card, the Rolling Player must roll 2 sixes, 1 five and 2 matching dice of any other number. The payout is \$700, but you only get 2 rolls to match those dice!



Chris opens the bid with \$100. Debbie bids \$200. Michelle calls out "\$500!" Debbie ups the bid to \$600. For Joe it's too risky – he chooses not to bid at all. Chris and Michelle drop out of the bidding. Debbie wins the bid.

Debbie is the Rolling Player. She places her bid amount – \$600 – in the bidding bin, and waits for her opponents to wager before she rolls the dice.

#### 2. Players Bet

Now Chris, Michelle and Joe must decide whether to bet, and how to bet – with Debbie or against her.

Chris doesn't think Debbie will match all of the dice. He turns his token "no"-side up and places a \$300 wager beside it. Michelle also bets "no" and wagers \$300. Joe bets "no" and wagers \$100.

### 3. Debbie Rolls

**1st roll:** Debbie rolls all 5 dice into the tray.

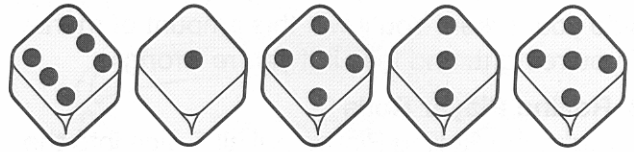

Debbie places the matching six and five on the card. She can't match the other five with a joker. She doesn't have to match a joker, but decides to do so with the three.



**2nd roll:** Debbie rerolls the remaining 2 dice.

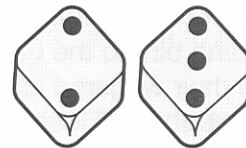

Debbie can't match the two, but she *must* match the three to the other joker. After using up her 2 rolls, Debbie was unsuccessful in completing the card.

Debbie loses her \$600 bid to the bank. From the bank, Chris and Michelle each get \$300 and Joe gets \$100 (the amount of their "no" wagers).

The 4 matched dice stay on the card. The next Rolling Player will roll 1 die twice to try to complete this card with a six.



### The Round Continues

Debbie (the previous Rolling Player) opens the bidding at \$200. Immediately Joe, Chris and Michelle call out higher and higher bids. Debbie joins in. Finally, Chris wins with a \$600 bid. So Chris becomes the Rolling Player, and places \$600 in the bidding bin.

Debbie and Michelle both bet “yes” with their tokens, and each wagers \$300. Joe bets “no” and wagers \$100.

### Chris Rolls

1st roll: Chris rolls 1 die.



He can't place it. He rolls again.

**2nd roll:** Yes! Chris rolls the six he needs!



Chris completes the card. He takes the card, reclaims his \$600 bid, and takes \$700 (the card's payout) from the bank. Debbie and Michelle each get \$300 for their “yes” wagers from the bank. Chris then gleefully takes Joe's \$100 “no” wager for himself! The round is over.



We will be happy to hear your questions or comments about this game. U.S. consumers please write to: Hasbro Games, Consumer Affairs Dept., P.O. BOX 200, PAWTUCKET, RI 0286. Tel: 888-836-7025 (toll-free). Canadian consumers please write to: Hasbro Canada Corporation, 2350 de la Province, Longueuil, QC Canada, J4G 1G2. Tel: 450-670-9820. European consumers please write to: Hasbro UK Ltd. Hasbro Consumer Affairs, P.O. Box 43, Caswell Way, Newport, Wales, NP19 4YD; or telephone our Helpline on 00 800 2242 7276

© 2005 Hasbro, Pawtucket, RI 02862. All Rights Reserved.

TM and © denote Reg. US Pat. & TM Office.

Designed by the McGuire Brothers.

42744

